

Medallions

Step 1:

Disconnect and remove light fixture before installing medallion over an existing fixture. Ensure electricity at fuse or circuit box is turned off before installing.

Step 2:

Drill center hole of medallion to allow wires to slip through for the connecting of light fixture to power source. Make sure hole is no larger than canopy cover. (You can also order your medallion pre-drilled from the factory by specifying size of center hole with your order – additional charges will apply).

Step 3:

Slip wires through medallion center-hole with canopy and ring loose.

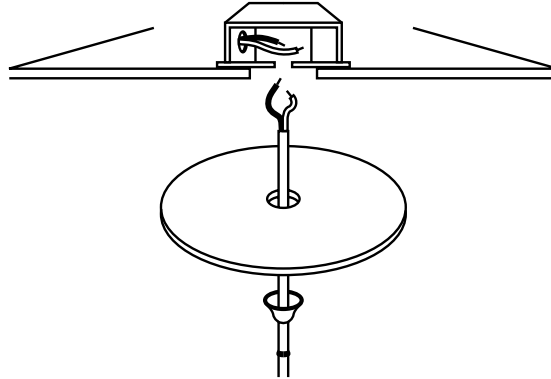

Step 4:

Connect fixture wires to power source. Slide medallion, canopy cover and ring up towards the ceiling. Tighten ring snug against medallion.

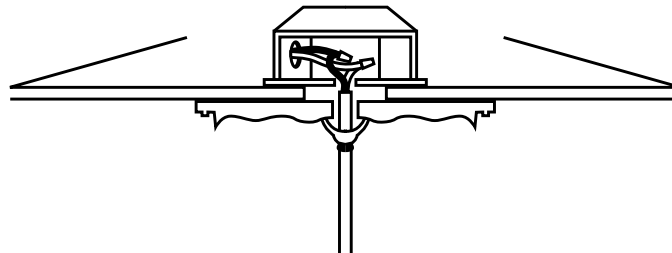

Step 5:

Use finishing nails or screws on the edges of the medallion in order that the medallion is flush all around the perimeter. The ring is the support for the fixture. The medallion should not be the support for the fixture. Chemcrest recommends not using adhesives in order that you may gain access to the electrical box in the future.

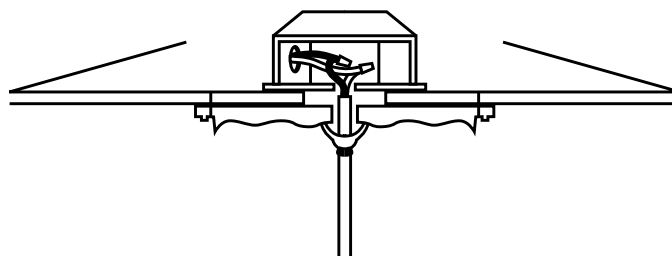

Step 6:

Counter sink finishing nails and fill holes with wood filler.

Step 7:

Paint medallion using a high quality latex or oil base paint.